

## IAC-06-D1.4.3

# SELF-SIMILAR MODULAR ARCHITECTURES FOR RECONFIGURABLE SPACE SYSTEMS

### **Afreen Siddiqi**

Post-Doctoral Research Associate, Department of Aeronautics/Astronautics  
Massachusetts Institute of Technology  
Cambridge, MA 02139, USA  
[siddiqi@mit.edu](mailto:siddiqi@mit.edu)

### **Olivier de Weck**

Associate Professor of Aeronautics/Astronautics and Engineering Systems  
Massachusetts Institute of Technology  
Cambridge, MA 02139, USA  
[deweck@mit.edu](mailto:deweck@mit.edu)

## **ABSTRACT**

Modular architectures have been increasingly favored for systems requiring some aspect of flexibility. A growing number of concepts, however, are being developed that have a specific kind of modular architecture in which the entire system is built of self-similar modules. In these systems each module or building block is identical (or very similar) either in external form, or both in form and function. The self-similarity allows for the highest degree of reconfigurability and is emerging to be a consistent choice for systems that need to fulfill multiple roles at different times, evolve easily to respond to new needs, and/or degrade gracefully over time. Since reconfigurability can allow for improving performance, efficiency, reliability, and flexibility of application, its manifestation through self-similar modular architecture for future space systems is studied in-depth in this paper. The systems analyzed in the study range from information processing (such as avionics) to mass transportation/supporting systems (such as spacecraft). Some of the advantages and disadvantages of this architecture are quantitatively analyzed through a case-study of a self-similar modular habitat for Moon and Mars missions. It is shown that self-similar modularity naturally allows for graceful degradation, system extensibility, and learning curve savings in production costs. There are however drawbacks of increased mass and module complexity.

## **1.0 INTRODUCTION**

Reconfigurability in future space systems, particularly those involved in the future exploration of Moon and Mars, is highly desirable [1]. Reconfigurable systems can fulfill multiple needs by carrying out different functions as required, evolve over time to meet new requirements, and continue functioning (possibly in degraded state) even in the presence of certain failures [2]. Reconfigurability in systems is often achieved through modular architectures [3]. Modularity is also a key enabler of several other beneficial qualities in a system (such as easy manufacturability, maintainability *etc.*) [4]. However, this paper explores modularity that is chiefly driven by the need to make a system reconfigurable. In these types of systems, a special case is that of *self-similar modular* architecture in which the entire system (or sub-system) is composed of identical modules. Such architectures are essentially a case of high intra-system commonality. This paper first discusses modularity in general and self-similar modular architectures in particular. A case study of spacecraft, based on truncated octahedron modules [5], is then used to quantitatively illustrate the main advantages and risks associated with self-similar modular systems.

### **1.1 Literature Review**

The movement towards modular thinking in space system design is largely motivated by cost considerations. Modularity enables designers to reduce cost by amortizing, over many missions, the cost of developing and producing common components [6]. Other potential benefits include faster development time (since different teams can work in parallel on different modules), cheaper test and validation processes, and easier future servicing and maintenance of the system [4]. In the past decade, more and more designs of spacecraft [7,8], surface habitats [9] and planetary surface rovers [10] *etc.* have been proposed with modular architectures. The designs have been motivated by the various advantages of modularity mentioned above.

More recently, as reconfigurability has been increasingly recognized to be an important quality for many space systems, various proposed concepts of reconfigurable spacecraft, rovers *etc.* have been modular in nature. A survey of several such concepts, however, reveals that those with the highest degree of reconfigurability tend to have self-similar modular architectures thereby allowing for radical changes in form and function as needed [3].

Self-similar modular architecture has been recognized as one that allows for natural extensibility [11]. This paper, however, focuses on several other aspects (in addition to extensibility) in order to provide an in-depth investigation of its benefits and potential disadvantages. A clear understanding of self-similar architecture in relation to reconfigurability, as this paper attempts to outline, will be a useful aid for system architects.

## **2.0 MODULAR ARCHITECTURES**

A module is an encapsulation of highly interconnected parts, whose external connections are minimized. This encapsulation is a function of the intent of modularity in the architecture [12]. A system designed to be modular for manufacturability may have the boundaries of its modules different from a system designed for future upgrades and maintainability. Similarly, the module boundaries will be defined in specific ways if the intent for modularity is system reconfigurability. An elegant modular architecture has identical or very similar boundaries for multiple intents.

In order to analyze various architectural aspects of modularity and reconfigurability, twelve different space systems were selected for analysis. Most of these systems are in the conceptual stage, however some have been built and flown in various missions. A brief description of each of these systems is given in the following section, and Appendix A provides illustrations/schematics of these systems for further detail.

### **2.1 Systems Description**

1. softSAT: This is a cluster based system of satellites, connected through inter-satellite links, that acts as a single satellite [8]. The cluster is composed of three different satellites, an antenna satellite, a modem and switch satellite, and a server satellite. The different technology obsolescence rates are thus managed by replacing only the relevant satellite in the cluster at various times.

2. TechSAT 21: This system concept is a cluster of smaller satellites that act together as one larger 'virtual satellite' [13]. Applications of such a cluster include synthesis of large apertures of varying sizes, adaptive beam patterns *etc.*

3. Self-Assembling Wireless Autonomously Reconfigurable Modules (SWARM): This is a spacecraft that is built from modules connected

through a common, ‘universal docking port’ [14]. Each module is a specific sub-system such as propulsion, attitude control *etc.*

4. SpaceFrame: The spaceFrame concept is that of ‘plug and play’ spacecraft [7]. It is a reconfigurable spacecraft architecture built around a modular set of mechanical blocks called SpaceFrame Blocks (SFB). These include a Core SFB (which is essentially the basic satellite bus), a payload SFB (capable of carrying any desired payload), Propulsion SFB, Deployable Solar Array SFB *etc.* The goal is to provide less expensive “modular” hardware solutions that allow for on-orbit configuration, servicing and upgrading.

5. Multi-mission Modular Spacecraft (MMS): This is a spacecraft platform designed by NASA in the 1970s [15]. The MMS had modules for propulsion, power, attitude control *etc.* The interfaces between the modules were different however. A few missions (such as the Solar Maximum Mission *etc.*) were flown with spacecraft built on this platform, however the MMS was abandoned due to the higher upfront costs [14].

6. Modular Roving Planetary Habitat, Laboratory, and Base (MORPHLAB): It is composed of power and habitat modules that land and assemble autonomously forming a long duration habitual base [9]. The hab modules are connected through inflatable tunnels. Once a manned mission phase is complete, the modules disassemble and move autonomously to an alternate lunar site. During transit, one power module would be connected to two habitable modules to form a vehicle assembly.

7. Polybot: These are modular, self-reconfigurable robots consisting of two types of modules: segments and nodes [16]. Most of the functionality is in the segments. The nodes allow for connecting segments in near arbitrary topologies. Potential applications include maintenance operations, and planetary surface mobility for exploration.

8. SWARM-bot: This is a self-assembling, self-organizing, metamorphic robotic system composed of several *s-bot* modules linked together [17]. Each *s-bot* is a fully autonomous mobile robot capable of navigation, motion, and grasping tasks. Potential applications include exploration, transport *etc.*

9. Planetary Surface Modular Robotic System (PSMRS): This consists of a group of modules that are assembled to produce a robot for a specific task [10]. The collection consists of a suite of power, actuation, kinematic and end-effector modules that are assembled to produce robots of

different capabilities for transport, exploration, soil manipulation *etc.*

10. Autonomous Nano-Technology SWARMS (ANTS): The ANTS basic structure is a robot consisting of identical, telescoping struts arranged in a tetrahedron shape, with electric motors placed at the corners [18]. The motors retract or expand the struts which produce motion of the robot. These tetrahedrons will join together in ‘swarms’ produce systems that can radically change shape and carry out diverse set of functions.

11. Ultra Long Life Avionics: This system consists of identical *generic function blocks*, communicating wirelessly that can be programmed to replace a wide variety of components in-flight [19]. The generic function blocks in the current prototype are essentially Field Programmable Gate Arrays (FPGAs).

12. Evolvable Hardware (EHW): These are self-reconfiguring electronic circuits based on Field Programmable Transistor Arrays (FPTAs) [20]. EHW can maintain functionality in the presence of faults and failures, due to radiation, temperature changes *etc.*, by reconfiguring the FPTAs through genetic evolutionary algorithms.

## 2.2 Architectural Analysis

Traditionally, modular systems have been classified on the basis of their interface types. Ulrich [21] has defined three different kinds of modularity: slot (different interfaces between modules), sectional (same interface between modules) and bus (all modules connect to a common *bus* via same type of interface). However, here both module and interfaces type are taken into consideration, along with the intent of modularity. The intent was specified from the literature/reference document of each system.

Table 1 shows the data for the surveyed systems. The four acronyms used in the ‘intent’ column are:

**E:** Evolution (future upgrades, servicing, *etc.*)

**F:** Functional reconfiguration

**D:** Graceful degradation (continued functionality in degraded state in presence of failures)

**M:** Manufacturability, ease of assembly and test, cost amortization through commonality.

The shaded rows are for systems that consist of only one type of module, *i.e.* are self-similar modular in architecture. It is interesting to note from Table 1 that all of these exhibit graceful degradation, and almost all exhibit functional reconfigurability as the intents for modularity.

**Table 1: Modular Space Systems**

	System	# of module types	Modularity type	Intent
1	softSAT	3	Sectional	E
2	TechSAT21	1	Sectional	F, E, D
3	SWARM	4	Sectional	M, F, E
4	Spaceframe	> 5	Slot	M
5	MMS	6	Slot	M, E
6	MORPHLAB	2	Sectional	F
7	Polybot	2	Sectional	F, D
8	SWARM-bot	1	Sectional	F, D
9	PSMRS	28	Slot	F, D
10	ANTS	1	Sectional	F, D
11	UL Avionics	1	Sectional	D
12	EHW	1	Sectional	D

If the systems are sorted in binary terms of commonality of interfaces and modules, then the following quad-chart (Table 2) is obtained. The upper left quadrant is for systems in which the modules are identical, and the interfaces between the modules are also same. The self-similar modular systems therefore occupy this space. Note that Ulrich’s classification is based on interface type and does not explicitly factor in module type. The slot modular systems will occupy the Different Interface column, while bus and sectional modular systems would be allotted the Same Interface column. Additional insights however can be obtained if both module and interface types are factored in for classification.

**Table 2: Quad-chart of Modules and Interfaces**

	Same Interface	Different Interface
Same Module	TechSAT 21 SWARM-bot ANTS UL Avionics EHW	
Different Module	softSAT SWARM polybot	Spaceframe MMS MORPHLAB PSMRS

Two main trends in architecture of modules can be noticed. In the case of different modules, (unshaded quadrants) the modules have distinct functions, *i.e.* the modules encapsulate a specific sub-system that provides a particular function to the rest of the system. Most of these have the underlying intent of allowing for easy future upgrades, cost amortization through commonality of modules across different missions *etc.*

In the case of same modules (shaded quadrants 1 and 2), each module encapsulates several

functions, and the overall system is composed of several of these modules that interact together. This is the self-similar modular case, in which each module is typically more complex as compared to modules in the first type of system described above, however it encapsulates the entire range of lower level functions that are necessary to produce the overall functionality of the system. It is interesting to note that we could not find an instance of a system that has identical modules, but different interfaces.

Figure 1, Figure 2 and Figure 3 show Object Process Diagrams (OPD) [22] of the MMS, softSAT, and TechSAT 21 systems that illustrate some of these observations. The ‘modules’ at the first level of decomposition in case of the MMS are various spacecraft sub-systems, in case of softSAT are the three smaller satellites, and in case of the virtual TechSAT21 satellite are the smaller identical satellites of the cluster.

The different shades for the satellite sub-systems in softSAT indicate that while each satellite has its own ADC, Power, C&DH module, these are not the same across the three satellites comprising the softSAT system. In a similar fashion, the sub-systems in the TechSAT 21 modules (satellites) are shaded the same to indicate that these are identical.

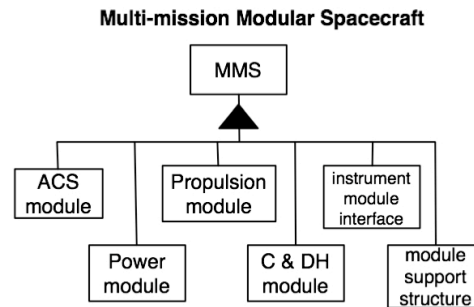

**Figure 1: OPD of MMS in which each module represents one sub-system**

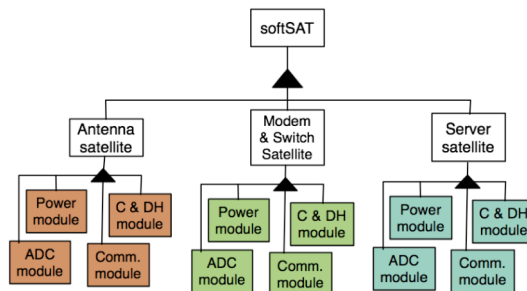

**Figure 2: OPD of softSAT composed of three different smaller satellites**

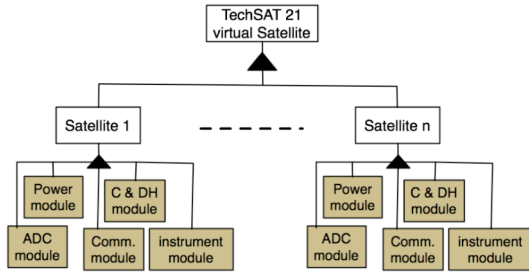

**Figure 3: OPD of TechSAT21 virtual satellite composed of identical smaller satellites**

On a relative scale, the MMS has the simplest modules (encapsulation of single function). The softSAT satellite is more complex, since its modules (the antenna, modem & switch, and server satellites) encapsulate more functionality, while the TechSAT 21 system has the most complex modules that are individually a complete independent system (satellite) in their own right.

The systems were also analyzed in terms of reconfiguration aspects. Table 3 shows the relevant data. The ‘reconfiguration outcomes’ column specifies if a change in Form Attribute (Fa), Process Attribute (Pa), or Process (Pr) results from reconfiguration [3]. ‘All’ indicates that all three outcomes are possible. The ‘Operation Cycle’ column indicates when the system can undergo a reconfiguration. If the system can reconfigure while carrying out its primary externally delivered function, it is considered to be reconfigurable *on-line* [3]. If, however it needs to be idle or shut down before it can reconfigure, then it is considered to be *off-line* reconfigurable [3].

**Table 3: Reconfiguration Characteristics**

	System	Reconfig Outcome	Operation Cycle
1	softSAT	Pa	Offline
2	TechSAT21	All	Online
3	SWARM	Pa	Online
4	Spaceframe	Pa	Offline
5	MMS	Pa	Offline
6	MORPHLAB	Fa, Pa	Offline
7	Polybot	All	Online
8	SWARM-bot	Fa, Pa	Online
9	PSMRS	All	Offline
10	ANTS	All	Online
11	UL Avionics	All	Online
12	EHW	All	Online

From Table 3 it can be easily seen that the self-similar modular systems (in shaded rows) exhibit higher degree of reconfigurability in the sense that they are capable of on-line reconfiguration and that

all three outcomes of reconfigurability are possible (unlike most other systems that are not self-similar modular).

### **3.0 SELF-SIMILAR MODULAR ARCHITECTURE**

As discussed previously, self-similar modular systems are easier to reconfigure in general. It is therefore useful to understand the type of reconfigurations to which this architecture is particularly amenable, along with the specific advantages and disadvantages it entails.

#### **3.1 Advantages**

In essence, self-similar modular architecture is the ultimate form of intra-system commonality since the entire system is composed of identical modules. The benefits of commonality can therefore be realized.

**3.1.1 Learning Curve Savings:** Commonality is often pursued for achieving cost reduction through learning curve savings and amortization over different missions. For instance, the MMS was designed to allow for cost savings across different spacecraft that were to be built with that platform [15]. In the self-similar modular case however, the savings can be realized even within each system’s development (instead of across different systems instances).

**3.1.2 Extensibility:** Extensibility is very natural to the self-similar modular architecture. Structural elements commonly utilize this property [23]. Many systems, especially for future exploration missions such as habitats for Moon and Mars missions of various durations can particularly benefit from this architecture.

**3.1.3 Graceful Degradation:** Another property that arises naturally for this architecture is graceful degradation. Since the system consists of identical modules, the loss or failure of a few can still allow the overall system to maintain functionality (perhaps at some degraded level). This quality is particularly important for long duration space missions. It is indeed interesting to note from Table 1 that graceful degradation is one of the intents for *all* the self-similar modular systems that were surveyed.

**3.1.4 Logistics Simplification:** Another important advantage for this architecture is that logistical

aspects can be greatly simplified. Common components can allow for significant reduction in required spares [24]. Part variety is reduced, and in most cases the modules can be line-replaceable units, both of which are highly desirable for manned space exploration missions.

**3.1.5 High Reconfigurability:** As shown in Table 3, self-similar modular architecture allows for comparatively easy reconfiguration and most of these systems can undergo online reconfiguration. Of all the systems surveyed in this analysis and in another wider set of reconfigurable systems [3], it has been observed that the systems capable of most radical changes in function and form are self-similar modular in their architecture.

Additionally, the modular approach in general allows use of much smaller launch vehicles. Even when larger launch vehicles are used that can launch multiple modules, there is manifest flexibility. For self-similar modules, the packing efficiency can be higher in many cases. There are thus potential advantages in terms of packing and launching such systems.

### 3.2 Disadvantages

**3.2.1 Mass and Volume Penalties:** While the high redundancies allow for graceful degradation in self-similar architecture, it also causes mass and volume penalties in many cases. This can be a significant trade off for space systems where mass and volume savings are highly desirable or even necessary due to launch vehicle constraints.

**3.2.2 Module Complexity:** Each module in this type of architecture usually encapsulates several different functions (and in some cases can operate independently in its own right as a smaller system). Consequently, the modules are more complex in this type of architecture as compared to others in which the modules encapsulate only a single sub-system.

**3.2.3 Fault Magnification:** Any design flaws or defects in the modules will be greatly enhanced, since the system will be composed of several of those modules. This risk-pooling effect due to the high commonality can be a serious issue for many space systems where high fault tolerance is often required. Also, it could be that failures in a self similar module propagate more easily to other parts of the system.

## 4.0 CASE-STUDY: TRANSFER AND SURFACE HAB

A case study of a Transfer and Surface Hab (TSH) for a manned Mars and Moon mission is presented here to quantitatively illustrate the benefits and disadvantages of self-similar architecture. The TSH for Mars transports a crew of 6 for 260 days in transit, and then supports them for 500 days on Mars surface. The lunar version of the TSH supports a crew of 4 for 5 days of travel and 180 days on the surface of the moon. The specific design that was considered in the analysis is one in which the habitat, fuel tank, and oxidizer tank of the vehicle are modular, and consist of several truncated octahedron shaped modules [5] (see Figure 4). These three sub-systems are thus self-similar modular. Note, that at the overall system (TSH) level the system uses different modules, but presumably identical interfaces (and would be in lower left quadrant of Table 2).

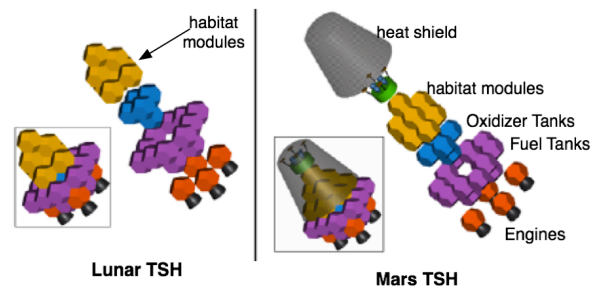

**Figure 4: Modular TSH for Moon and Mars [5]**

The optimal modular design obtained in [5] is used in this case study (see Table 4), and only the habitat section is considered here as the self-similar modular system. It should be noted that the lunar and Mars vehicles utilize the same modules, although in different numbers in order to provide adequate pressurized volume for their respective crew size and mission durations.

**Table 4: Habitat Modules Data in TSH**

	<b>Mars</b>	<b>Moon</b>
# of Crew	6	4
Mission [days]	760	185
# Hab Modules	12	8
Module Pressurized Volume [m <sup>3</sup> ]	28.6	28.6
Total Hab Volume [m <sup>3</sup> ]	343	228
Module Dry Mass [kg]	3,239	3,239
Module Consumable Mass [kg]	2,463	596
Total Module Mass [kg]	5,702	3,835
Total Hab Mass [kg]	68,422	30,679

#### 4.1 Degradation and Survivability

In the lunar variant for the TSH, there are 8 habitat modules that provide a total of 228 m<sup>3</sup> of pressurized volume to a crew of 4, while the Mars TSH has 12 habitat modules providing a volume of 343 m<sup>3</sup>. The required volume (and number of modules) was determined by assuming that each person optimally requires 19m<sup>3</sup> of volume (for a 180 day mission) [25]. The total pressurized volume required for the mission,  $V_{tot}$ , was obtained from [5]:

$$V_{tot\_opt} = 3V_{opt}N_{crew} \quad (1)$$

In the optimal case  $V_{opt}$  was 19 m<sup>3</sup>. For considering survivability scenarios, the smallest volume ( $V_{min}$ ) for the ‘performance limit’ for a crew can be used [25]. Thus, the total required volume in that case is:

$$V_{tot\_min} = 3V_{min}N_{crew} \quad (2)$$

Dividing  $V_{tot\_min}$  by pressurized volume of one habitat module ( $V_{mod}$ ) gives the minimum number of modules,  $N_{mod\_min}$  that must function in order to provide the smallest allowed volume to the crew:

$$N_{mod\_min} = \left\lceil \frac{V_{tot\_min}}{V_{mod}} \right\rceil \quad (3)$$

The ceiling brackets in Equation 3 denote that the result of the division is rounded up to the next integer.

For the Mars mission,  $N_{crew}$  is 6,  $V_{min}$  is 11 m<sup>3</sup> [25], and  $V_{mod}$  is 28.6 m<sup>3</sup>. This makes  $N_{mod\_min}$  to be 7, *i.e.* 7 modules must function out of the 12 total habitat modules so that the crew has enough volume to be able to perform their required functions and survive the mission. In other words, a total of up to 5 modules can fail (from the 12 habitat modules) and the system can still support the crew at some basic level.

Similarly, for the 180-day lunar mission,  $N_{crew}$  is 4,  $V_{min}$  is 11 m<sup>3</sup> [25], and  $V_{mod}$  is 28.6 m<sup>3</sup>. In this case,  $N_{mod\_min}$  is 5. Thus, out of the total 8 habitat modules at least 5 must be available while 3 can fail. There is a subtlety which is ideally that the remaining functioning modules should remain a connected set so the crew can move from one to the other without doing EVA.

The modular habitat designs for Moon and Mars missions were then compared with non-modular habitat design in order to assess the tradeoffs of self-similar modular architecture. The non-modular design will be loosely referred to as ‘integral’. It can potentially however be an architecture of the type shown in Figure 1 where there are several modules that comprise the overall system, but each module serves one particular sub-system.

The first thing to note in the modular case is that the total pressurized volume is provided by a series of connected habitat modules. Since the truncated octahedron modules are independent, a loss of one module only renders its particular volume uninhabitable. The rest are not affected. In such a case for example, even if up to 3 modules fail in the lunar TSH, the remaining 5 modules will still have enough pressurized space to sustain a crew of 4 for 180 days. In the integral case, however, due to the nature of the design a partial loss of habitable volume cannot be considered. If the life support system is lost, or some other failure occurs such that it becomes uninhabitable the entire pressurized area is ‘lost’ since it is one integrated space. The advantage of the self-similar architecture in terms of its inherent ability to provide graceful degradation is therefore clearly evident here.

Some additional analyses in terms of reliability requirements can also be performed. Assume that the integral habitat has a reliability  $R_{int}$ , which is the probability that it can successfully sustain the crew for the desired period. The modular case can be compared in two ways:

1. If all the  $N$  modules combined should have an overall reliability of  $R_{int}$ , then it means that each individual module should have (higher) reliability,  $R_{mod}$ :

$$\begin{aligned} R_{mod}^N &= R_{int} \\ R_{mod} &= (R_{int})^{1/N} \end{aligned} \quad (4)$$

For instance, if  $R_{int}$  is 99.90% and  $N$  is 8, then  $R_{mod}$  will be 99.98%. Thus, the modules need to have higher reliability than the integral habitat in order to ensure that the same amount of space is available to the crew. This is shown in Figure 5 for both Moon and Mars cases for varying  $R_{int}$ .

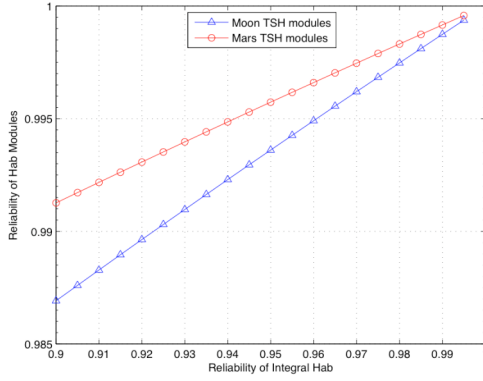

**Figure 5: Integral and Modular Reliability Comparison**

2. A second comparison can be made on the basis of gradual degradation of the available space being possible in the modular case. A question can therefore be posed that what should the reliability of the modules be, such that there is  $R_{int}$  chance that at least enough modules are functioning to provide the *minimum sustainable volume* for the crew. Note that this is essentially a different comparison from the first case. In the first case the comparison is made for modular and integral architectures such that both types provide same amount of habitable volume for the crew. In this case however, the comparison is made such that the integral case provides the full habitable volume, while the modular case is allowed to provide lesser volume, but to the extent that the crew can be sustained for duration of the mission. The lesser volume case is considered due to the inherent capability of the modular architectural to undergo gradual degradation.

Suppose, if  $R_{int}$ , of 99.9% is required such that a minimum sustainable volume remains for the crew, then a failure of up to  $N_f$  modules can be tolerated:

$$(1 - R_{mod})^{N_f} = 1 - R_{int} \quad (5)$$

As calculated above, even after 3 failures for the lunar mission and 5 failures for the Mars mission, there is sufficient space left for the crew to continue with reasonable performance. For  $R_{int}$  of 99.9% and  $N_f$  of 3,  $R_{mod}$  is found to be 90%. In other words, the modules need to have only 90% reliability so that an overall chance of 99.9% remains that at least enough modules will function to provide minimum sustainable volume to the crew.

The reliability of the individual modules can be lower than that required for the integral habitat. Figure 6 shows this with plots of how  $R_{mod}$  varies for different values of  $R_{int}$  for modules used in TSH for Moon and Mars missions.

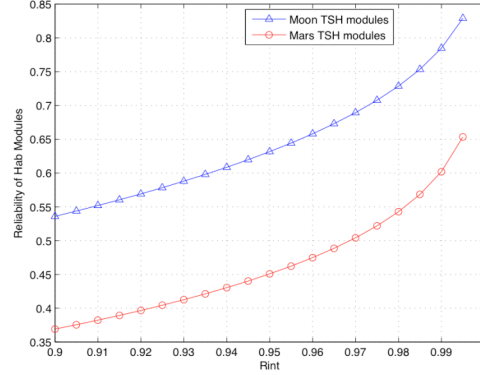

**Figure 6: Reliability Comparison for Minimum Habitable Volume**

It can be seen for instance that if  $R_{int}$  is 97% (which means that integral habitat should have 97% reliability), then each module for the Moon TSH can have only 70% reliability to ensure that there is overall 97% chance of minimum habitable volume being available to crew during the mission. The subtlety should be noted that the integral case provides the full 228 m<sup>3</sup> volume with 97% reliability, while the modular case has 97% reliability of having at least 5 of the 8 modules functioning and thereby providing at least 143 m<sup>3</sup> which is the minimum sustainable volume.

#### 4.2 Development and Production Cost

A major factor in pursuing commonality and modularity in systems is cost reduction. This section provides a first order model (based on spacecraft cost modeling assumptions in [26]) for the potential savings that can result from self-similar modular architecture as compared to an integral case.

In the modular case, learning curve savings need to be included, since the habitat consists of several identical modules. The production cost,  $P_{mod}$ , for  $N_{mod}$  units that are used in the modular habitat can be computed as:

$$\begin{aligned} P_{mod} &= TFU_{mod} L_{mod} \\ L_{mod} &= N_{mod}^{B_1} \\ B_1 &= 1 - \frac{\ln(100/S_1)}{\ln(2)} \end{aligned} \quad (6)$$



where  $S_l$  (the learning curve slope) is 90% [26],  $TFU_{mod}$  is the theoretical first unit cost of producing a single habitat module, and  $L_{mod}$  is the learning curve factor for building the complete habitat. If the cost of one Moon and one Mars habitat is to be determined, then  $N_{mod}$  is simply the sum of modules used in the two vehicles (due to the modules being identical).

The Research Development Test and Evaluation (RDT&E) cost will be incurred only once since the same type of module is used for lunar and Mars missions. For high-tech programs a factor of 5 or 6 times the TFU cost is typically used to estimate the RDT&E of un-manned spacecraft [26]. It can therefore be assumed for the modular case that  $RDTE_{mod}$  is a linear function of the TFU, thus:

$$RDTE_{mod} = \alpha_1 TFU_{mod} \quad (7)$$

The RDT&E cost plus the production cost for one modular lunar and one modular Martian habitat, denoted as  $C_{mod}$ , is then:

$$C_{mod} = \alpha_1 TFU_{mod} + P_{mod} \quad (8)$$

$$C_{mod} = (\alpha_1 + L_{mod}) TFU_{mod} \quad (9)$$

A similar parameterized model for the integral habitat case can be developed, however in this case the RDT&E costs will be incurred for both the lunar and mars vehicles separately. There will also be no learning curve savings when considering the costs of production of a single vehicle for each of the missions. The sum of RDT&E cost and production cost of one vehicle each, denoted as  $C_I$ , is then:

$$C_I = RDTE_{moon} + TFU_{moon} + RDTE_{mars} + TFU_{mars} \quad (10)$$

where

$$RDTE_{moon} = \alpha_2 TFU_{moon} \quad (11)$$

$$RDTE_{mars} = \alpha_3 TFU_{mars}$$

If it is assumed that the  $TFU_{mars}$  is some factor of  $TFU_{moon}$  since there will be similarities (commonality) between the vehicles, then:

$$TFU_{mars} = \beta TFU_{moon} \quad (12)$$

Thus,

$$RDTE_{mars} = \alpha_3 \beta TFU_{moon} \quad (13)$$

Using these relations the expression for  $C_I$  becomes:

$$C_I = (\alpha_2 + 1 + \alpha_3 \beta + \beta) TFU_{moon} \quad (14)$$

Equations 9 and 14 can now be used to compare the modular and integral cases.

In order to estimate the values of alphas and  $\beta$ , the Spacecraft /Vehicle Level Cost Model (SVLCM), that has been derived from the NASA/Airforce Cost Model (NASCOM) database, was used [27]. This model computes the development and production costs of different kinds of spacecraft based on their dry mass. Using the dry mass of a module (of 3239 kg) in the cost model, Eq. (7) was used to find the value of  $\alpha_1$ . It was computed to be 12.85. Note that as mentioned earlier, for unmanned spacecraft  $\alpha$  can be estimated to be 5 or 6, however for manned spacecraft it was found to be higher. The values for  $\alpha_2$ ,  $\alpha_3$ , and  $\beta$  were found in a similar fashion using dry mass values of 62,070 kg and 23,584 kg for the integral Mars and Moon habitats respectively.  $\alpha_2$  was determined to be 10.28,  $\alpha_3$  was 9.23 and  $\beta$  was 1.89.

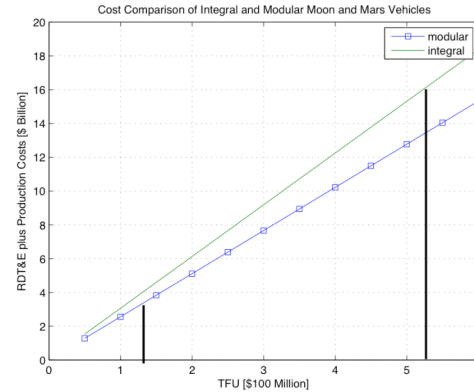
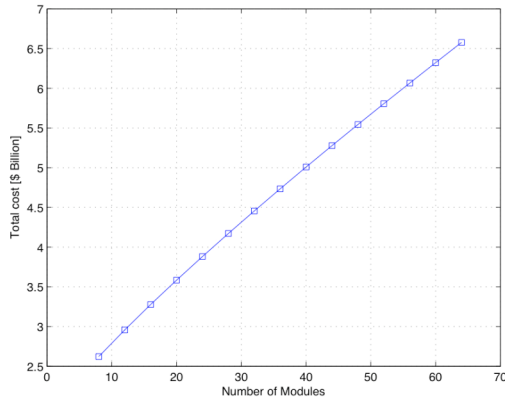

**Figure 7: Cost Comparison of Modular and Integral Habitats**

Figure 7 shows how  $C_{mod}$  (from Eq. 9) and  $C_I$  (from Eq. 14) compare as a function of varying TFUs. The line with square markers is for  $C_{mod}$  and the solid line is for  $C_I$ . Note that each of these is the RDT&E and production cost of one set of moon and mars vehicles. It can be seen that if the TFU for both the cases is close to \$100 Million, then  $C_I$  and  $C_{mod}$  are similar. However, in reality the  $TFU_{mod}$  and  $TFU_{moon}$  can be expected to be quite different due to significant differences in the dry masses. The SVLCM predicted a  $TFU_{mod}$  of \$140.3 million FY06, and  $TFU_{moon}$  of \$522.95 Million FY 06. One set of modular Moon and Mars TSH therefore costs over \$3.5 billion, while one set of integral moon and mars TSH will cost \$16 billion. The modular case is cheaper by an order of magnitude. The cost values however need to be treated with caution since the

SVLCM is a model based on existing data of spacecraft which may not be an accurate representation for future vehicles.

Figure 8 shows how  $C_{mod}$  varies as a function of number of modules produced while Figure 9 shows  $C_I$  for different combinations of Moon and Mars TSH. It can be observed for instance from these charts that for \$6 Billion FY06, 56 modules can be produced (see Figure 8), while only one integral Moon vehicle can be produced (see Figure 9). The 56 modules can translate into 7 modular habitats for the Moon (each use 8 modules), or 4 Mars (48 modules) and 1 Moon (8 modules) TSH etc. It is clear that the modular case can offer large savings in the production and development cost if the same modules can be used for Moon and Mars missions.



**Figure 8:  $C_{mod}$  as a Function of Number of Habitat Modules**

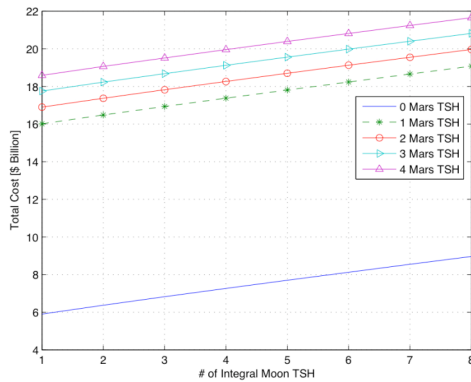

**Figure 9:  $C_I$  for Varying Combinations of Integral Moon and Mars TSH**

### 4.3 Mass Comparison

It was discussed earlier that modular systems can have greater mass than an equivalent integral system. In the truncated octahedron modules based spacecraft, it was previously assumed that there was a

structural modularity factor,  $f_{mod}$  of 10%, which accounts for the overall structural mass increase from the additional structure required to enclose smaller volumes than the integral case [5]. Also, a docking penalty,  $m_{dock}$ , of 400 kg per module was assumed [5]. This mass penalty accounts for standardized docking hardware between modules and extra hardware required for the facilitation of electronic, thermal, environmental *etc.* transport between modules. Consequently, the self-similar modular design has a higher mass. For the Mars TSH, the integral habitat is 62,070 kg [5], while the modular habitat is 68,422 kg. There is thus a mass penalty of 6.3 metric tonnes for the self-similar modular design. This mass penalty will translate into higher transportation costs that need to be factored in and traded against the cost savings there were discussed in the previous section. Since transportation/launch costs are significant for space systems, the production cost savings can potentially be offset by the increased transportation costs.

## 5.0 CONCLUSIONS

This study shows through a survey of various concepts and prototype space systems that self-similar modularity is the architecture of choice in systems with greatest degree of reconfigurability. These systems can undergo radical changes in form and function, and easily allow for online reconfiguration capabilities.

Self-similar modular architecture provides specific benefits in terms of graceful degradation, learning cost savings, and natural extensibility among others. These advantages however need to be traded against potential drawbacks of increased mass and higher module and system complexity. The self-similar modularity merits attention for certain types of space systems (such as long duration human missions) in which survivability and extensibility are particularly important. A case study of a self-similar modular habitat section in a Transfer and Surface Hab (TSH) concept serves to quantitatively illustrate some of the key points discussed in this paper.

In future studies, other types of systems, such as earth-orbiting satellites, will be investigated for further analysis. Additionally, some of the advantages and disadvantages of self-similarity (listed in Section 3) that were not addressed in the present case study will be further developed for quantitative analysis.

## 6.0 APPENDIX

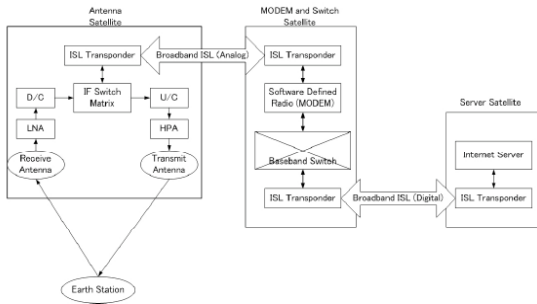

Figure 10: The softSAT concept [8]

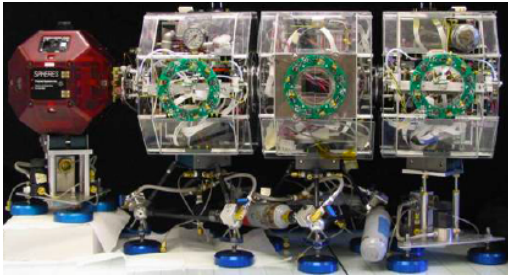

Figure 11: SWARM [14]

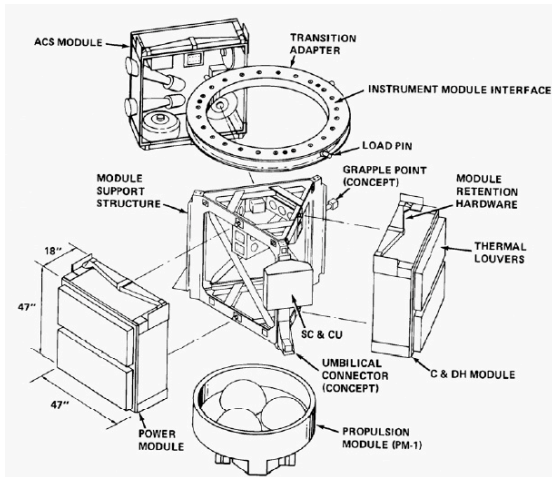

Figure 12: Multimission Modular Spacecraft [15]

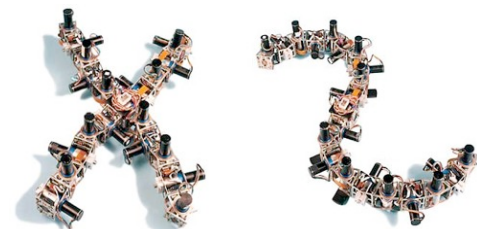

Figure 13: Polybot [16]

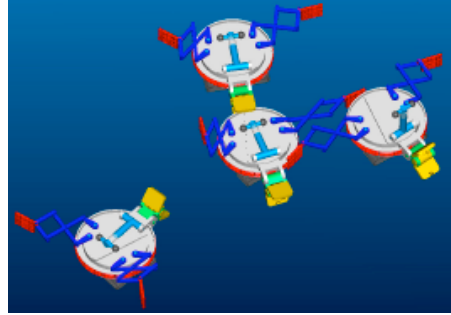

Figure 14: SWARM-bot system consisting of s-bot modules [17]

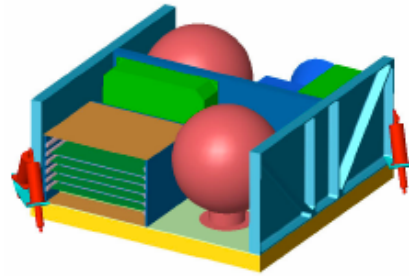

Figure 15: Modular spacecraft based on spaceFrame Blocks [7]

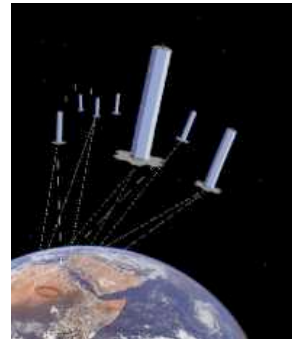

Figure 16: TechSat 21 satellite cluster [28]



Figure 17: Tetrahedron module in ANTS system [18]

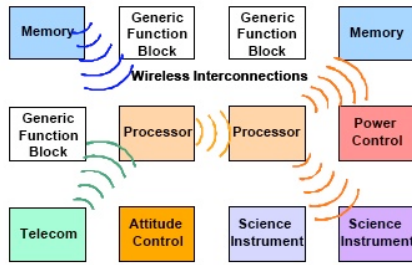

Figure 18: Spacecraft Avionics based on generic function blocks [19]



Figure 19: Planetary Surface Modular Robot [10]

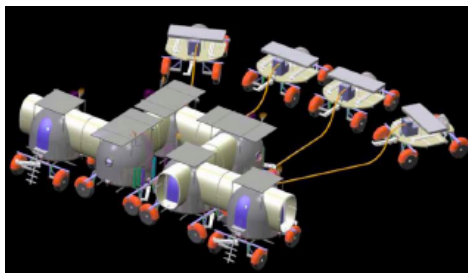

Figure 20: MORPHLAB [9]

## References:

- [1] Marzwell, N.I., et al. "How to Extend the Capabilities of Space Systems for Long Duration Space Exploration Systems", Space Technology and Applications International Forum-STAIF 2005, CP746, 2005
- [2] Siddiqi A., de Weck O.L., and Hoffman, J., "Sustainability in System Architectures Through Reconfigurability: A Case Study of Planetary Surface Vehicles", IAC-05-D3.3.03, 56th International Astronautical Congress, Fukuoka, Japan, Oct 17-21, 2005
- [3] Siddiqi, A. *Reconfigurability in Space Systems: Architecting Framework and Case Studies*. PhD Thesis. Massachusetts Institute of Technology, May 2006.

[4] Ulrich, K.T., and Eppinger, S.D., *Product Design and Development*, McGraw-Hill, 1995.

[5] de Weck, O. L., et al. "Modular Structures for Manned Space Exploration: The Truncated Octahedron as a Building Block", 1<sup>st</sup> Space Exploration Conference: Continuing the Voyage of Discovery, 30 Jan – 1 Feb 2005, Orlando, FL

[6] Ulrich, K. and Tung, K., "Fundamentals of Product Modularity", ASME Issues in Design Manufacture/Integration, Vol. 39, Atlanta, Georgia, December 1991, pp. 73-79.

[7] Miller, J., Guerrero, J., et al. "SpaceFrame: Modular Spacecraft Building Blocks for Plug and Play Spacecraft". 16th Annual/ USU Conference on Small Satellites, Utah. 2002

[8] Nishinaga, N., Ogawa, Y. et al. "SOFTSAT: Reconfigurable Communication Satellite System". 21st International Communication Satellite Systems Conference and Exhibit, Yokohama, Japan, 2003. AIAA 2003-2420

[9] Zakrajsek, J.J., et al. "Exploration Rover Concepts and Development Challenges", AIAA-2005-2525, 1<sup>st</sup> Space Exploration Conference: Continuing the Voyage of Discovery, 30 Jan-1 Feb, 2005, Orlando, Florida

[10] Farritor, S and Zhang, J., "Modular Robotic Infrastructure to Support Planetary Surface Operations", AIAA-2000-5135.

[11] Fricke, E. and Schulz, A.P "Design for changeability (DfC): Principles to enable changes in systems throughout their entire lifecycle" Systems Engineering, Vol 8, Issue 4, 2005.

[12] Crawley, E. Fall 2003, Systems Architecture Lecture Notes, MIT, September 2003.

[13] Martin, M., and Stallard, M. J., "Distributed Satellite Missions and Technologies – The TechSAT 21 Program", AIAA-99-4479, AIAA Space Technology Conference and Exposition, 28-30 September, 1999, Albuquerque, NM.

[14] Rodgers, L. *Concepts and Technology Development for the Autonomous Assembly and Reconfiguration of Modular Space Systems*. S.M Thesis. Massachusetts Institute of Technology, 2005.

- [15] Schindler, W.R., and Raab, B., “*Multi-mission modular spacecraft/MMS/ - A natural extension of STS*”, EASCON '80; Electronics and Aerospace Systems Conference
- [16] Yim, M et al., *Modular Reconfigurable Robots in Space Applications*, Autonomous Robots, Vol 14, No. 2-3, March/May, 2003, pp 225-237.
- [17] Mondada, F., et. al., “*Search for Rescue: An Application for the SWARM-BOT Self-Assembling Robot Concept*”, Technical Report, I2S – LSA – STI, Swiss Federal Institute of Technology, Lausanne, Switzerland, September 2002
- [18] Clark, P.E. and Rilee, M.I., “*BEES for ANTS: Space Mission Applications for the Autonomous Nano Technology Swarm*”, AIAA-2004-6303, AIAA 1st Intelligent Systems Technical Conference, 2004
- [19] Chau, S.N et. al., “*Ultra Long-life Spacecraft for Long Duration Space Exploration Missions*”, IAC-02-U.2.05, 53rd International Astronautical Congress, 2002
- [20] Stoica, A., et al., “*Evolvable, Reconfigurable Hardware for Future Space Systems*”, IAC 02-U.1.07, 53rd International Astronautical Congress, 2002
- [21] Ulrich, K., “*The Role of Product Architecture in the Manufacturing Firm*”, Research Policy, 1995, Vol. 24, pp. 419-440
- [22] Dori, D., “*Object Process Methodology*”, Springer, 2002
- [23] Dyskin, A.V., et. al., “*The Principle of Topological Interlocking in Extraterrestrial Construction*”, Acta Astronautica, 2005, Vol. 57, pp.10-21
- [24] Siddiqi, A. and de Weck, O.L., “*Spare Parts Requirements for Space Missions with Reconfigurability and Commonality*”, to appear in AIAA Journal of Spacecraft and Rockets.
- [25] Woolford, B and Bond, R.L., “*Human Factors of Crewed Spaceflight*”, “*Human Spaceflight Mission Analysis and Design*”, edited W. J. Larson and L. K. Pranke, McGraw Hill, New York, New York, 1999, pp. 149-150.
- [26] Wertz, J.R. and Larson, W.J., *Space Mission Analysis and Design*, 3<sup>rd</sup> edition, Space Technology Series, Microcosm Press and Kluwer Academic Publishers, 1999, pp. 809-810.
- [27] URL:  
<http://www1.jsc.nasa.gov/bu2/SVLCM.html>  
 Accessed: September 14, 2006
- [28] URL:  
<http://ssl.mit.edu/spheres/images/techsat21-2.jpg>  
 Accessed: August 27, 2006